

HILTI

TE 46/TE 46-ATC TE 56/TE 56-ATC

Operating instructions

en

Mode d'emploi

fr

Manual de instrucciones

es

Manual de instruções

pt



369440

1

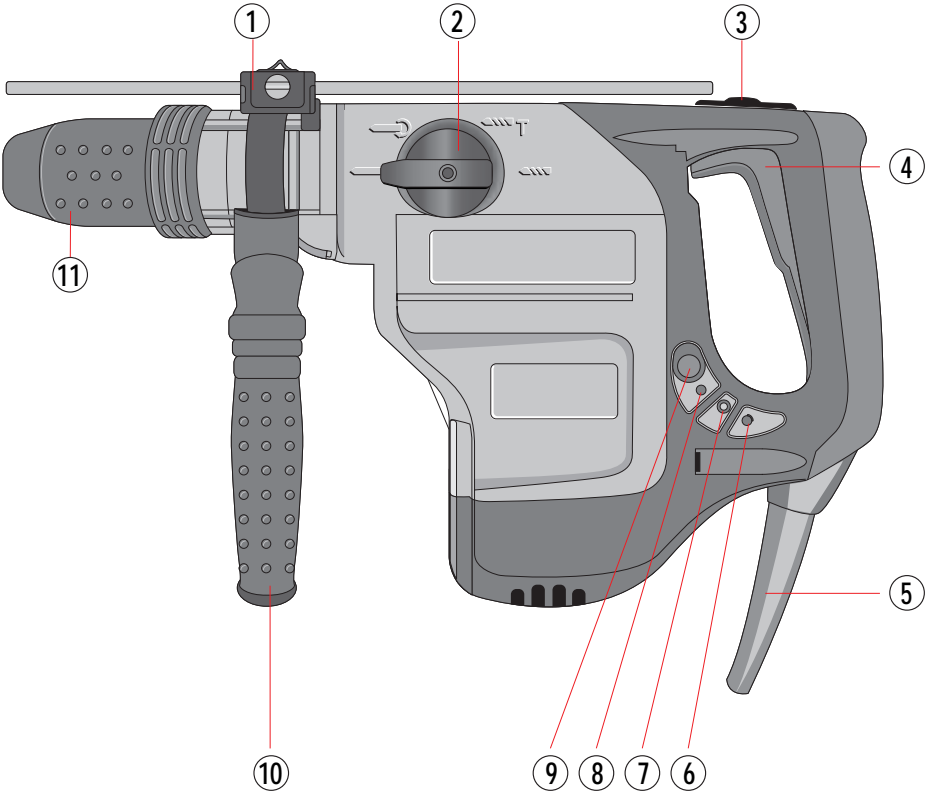
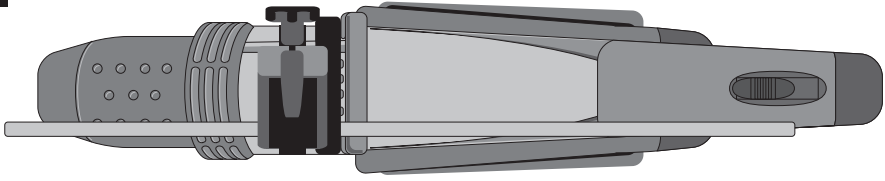

UL listed to US and Canadian safety standards
Homologué UL (conforme aux normes de sécurité américaines et canadiennes)
Producto homologado según normas de seguridad americanas y canadienses
Produto homologado de acordo com as normas de segurança americanas e canadianas



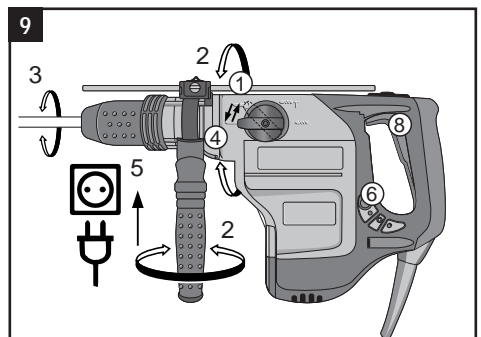
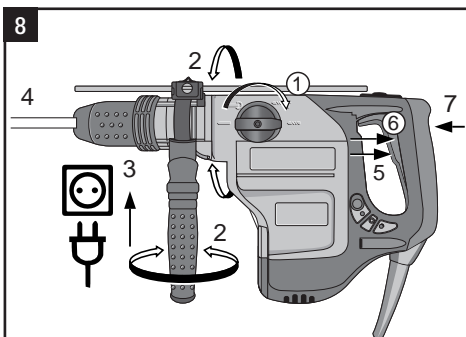
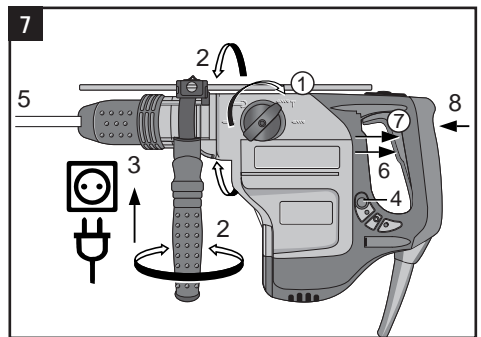
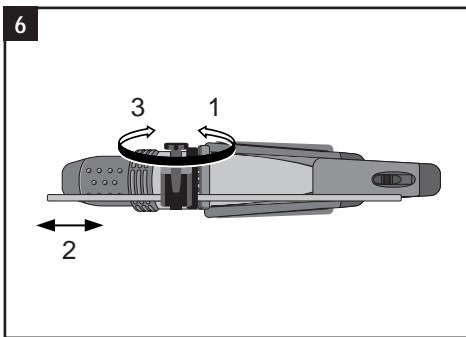
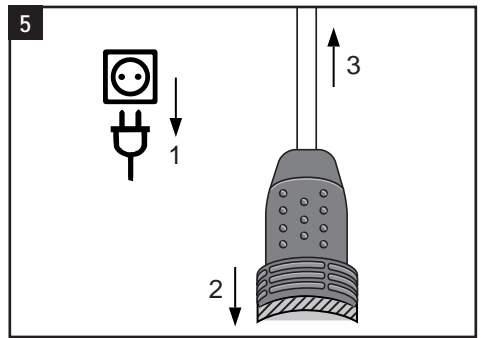
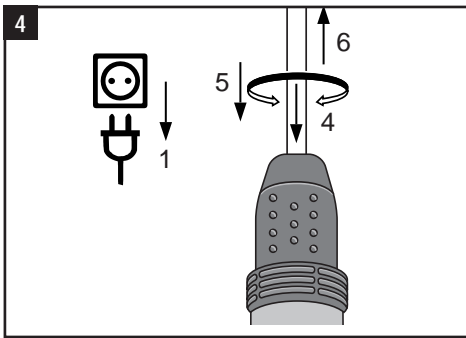
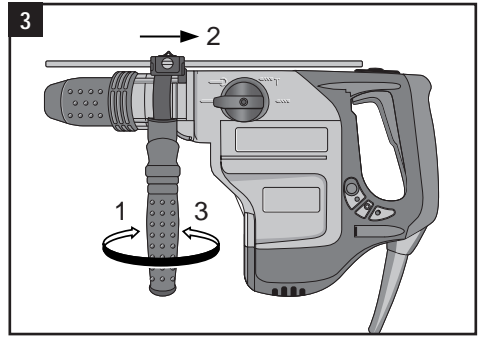
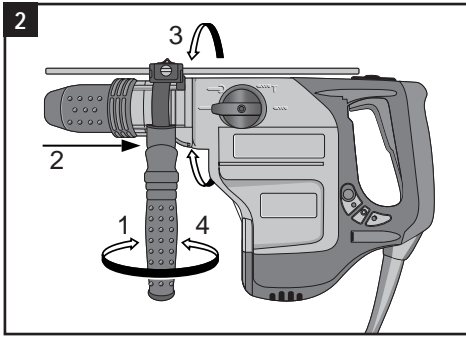

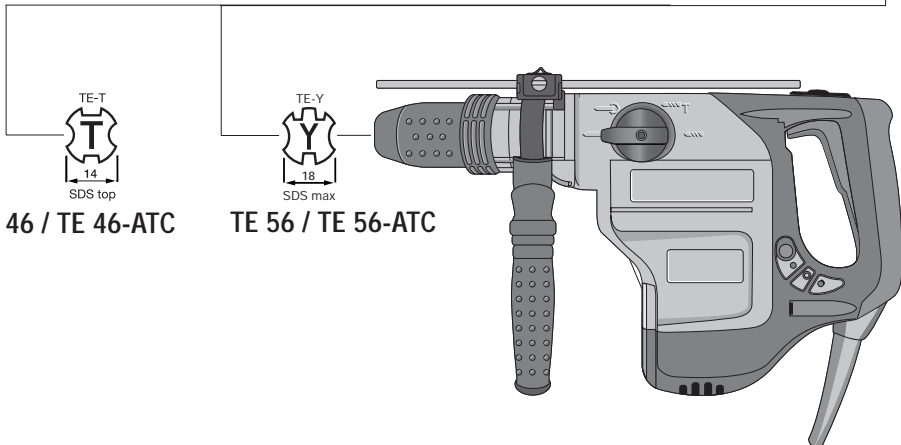
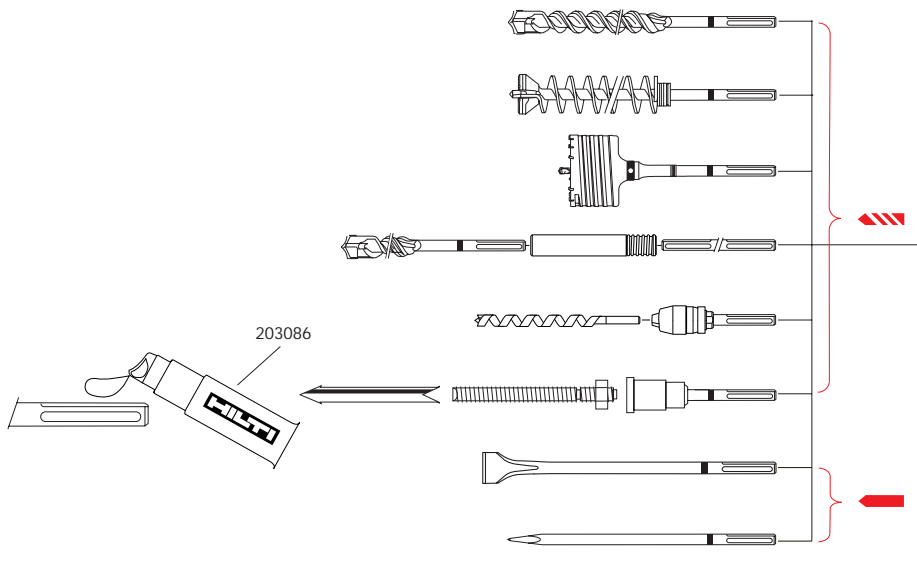

TE 46 / TE 46-ATC

TE 56 / TE 56-ATC

TE 46/TE 46-ATC/TE 56/TE 56-ATC combihammer

It is essential that the operating instructions are read before the tool is operated for the first time.

Always keep these operating instructions together with the tool.

Ensure that the operating instructions are with the tool when it is given to other persons.

Operating controls and components 1

- ① Removable depth gauge
- ② Function selection switch
- ③ Control switch lockbutton
- ④ Control switch
- ⑤ Supply cord
- ⑥ Activation indicator (anti-theft device)
- ⑦ Service indicator
- ⑧ Indicator for reduced power (50%)
- ⑨ Switch for reduced power (50%)
- ⑩ Side handle
- ⑪ Chuck

Contents	Page
1. General information	1
2. General safety rules	2
3. Specific safety rules and symbols	3
4. Functional description	3
5. Assembly	5
6. Operation	5
7. Care and maintenance	7
8. Tools and accessories	8
9. Troubleshooting	8
10. Disposal	9
11. Warranty	9

1. General information

1.1 Signal words and their meaning

-CAUTION-

Used to draw attention to a potentially dangerous situation which could lead to minor personal injury or damage to the equipment or other property.

-NOTE-

Used to draw attention to an instruction or other useful information.

1.2 Pictograms

Warning signs



General warning



Warning: electricity



Warning: hot surface

Obligation signs



Wear a safety helmet



Wear eye protection



Wear breathing protection



Wear ear protection



Wear protective gloves

Symbols



Read the operating instructions before use.

1 These numbers refer to the corresponding illustrations. The illustrations can be found on the fold-out cover pages. Keep these pages open while studying the operating instructions.

In these operating instructions, the TE 46/TE 46-ATC/TE 56/TE 56-ATC combihammer is referred to as "the tool".

Location of identification data on the tool

The type designation can be found on the rating plate and the serial number on the side of the motor housing. Make a note of this data in your operating instructions and always refer to it when making an enquiry to your Hilti representative or service department.

Type: _____

Serial no.: _____

2. General safety rules

1. WARNING!

Read and understand all instructions.

Failure to follow all instructions listed below may result in electric shock, fire and/or serious personal injury.

SAVE THESE INSTRUCTIONS

2. Work Area

Keep your work area clean and well lit. Cluttered benches and dark areas invite accidents.

Do not operate power tools in explosive atmospheres, such as in the presence of flammable liquids, gases, or dust. Power tools create sparks which may ignite the dust or fumes.

Keep bystanders, children and visitors away while operating a power tool. Distractions can cause you to lose control.

3. Electrical Safety

Grounded tools must be plugged into an outlet properly installed and grounded in accordance with all codes and ordinances. Never remove the grounding prong or modify the plug in any way. Do not use any adaptor plugs. Check with a qualified electrician if you are in doubt as to whether the outlet is properly grounded. If the tools should electrically malfunction or break down, grounding provides a low resistance path to carry electricity away from the user.

Applicable only to Class I (grounded) tools.

Double Insulated tools are equipped with a polarized plug (one blade is wider than the other.) This plug will fit in a polarized outlet only one way. If the plug does not fit fully in the outlet, reverse the plug. If it still does not fit, contact a qualified electrician to install a polarized outlet. Do not change the plug in any way. Double Insulation  eliminates the need for the three wire grounded power cord and grounded power supply system.

Applicable only to Class II tools.

Avoid body contact with grounded surfaces such as pipes, radiators, ranges and refrigerators. There is an increased risk of electric shock if your body is grounded.

Don't expose power tools to rain or wet conditions. Water entering a power tool will increase the risk of electric shock.

Do not abuse the cord. Never use the cord to carry the tools or pull the plug from an outlet. Keep cord away from heat, oil, sharp edges or moving parts. Replace damaged cords immediately. Damaged cords increase the risk of electric shock.

When operating a power tool outside, use an outdoor extension cord marked «W-A» or «W». These cords are rated for outdoor use and reduce the risk of electric shock.

4. Personal Safety

Stay alert, watch what you are doing and use common sense when operating a power tool. Do not use a tool while tired or under the influence of drugs, alcohol, or medication. A moment of inattention while operating power tools may result in serious personal injury.

Dress properly. Do not wear loose clothing or jewelry. Contain long hair. Keep your hair, clothing, and gloves away from moving parts. Loose clothes, jewelry, or long hair can be caught in moving parts.

Avoid accidental starting. Be sure switch is off before plugging in. Carrying tools with your finger on the switch or plugging in tools that have the switch on invites accidents.

Remove adjusting keys or wrenches before turning the tool on. A wrench or a key that is left attached to a rotating part of the tool may result in personal injury.

Do not overreach. Keep proper footing and balance at all times. Proper footing and balance enables better control of the tool in unexpected situations.



Use safety equipment. Always wear eye protection. Dust mask, non-skid safety shoes, hard hat, or hearing protection must be used for appropriate conditions.

5. Tool Use and Care

Use clamps or other practical way to secure and support the workpiece to a stable platform. Holding the work by hand or against your body is unstable and may lead to loss of control.

Do not force tool. Use the correct tool for your application. The correct tool will do the job better and safer at the rate for which it is designed.

Do not use tool if the switch does not turn it on or off. Any tool that cannot be controlled with the switch is dangerous and must be repaired.

Disconnect the plug from the power source before making any adjustments, changing accessories, or storing the tool. Such preventive safety measures reduce the risk of starting the tool accidentally.

Store idle tools out of reach of children and other untrained persons. Tools are dangerous in the hands of untrained users.

Maintain tools with care. Keep cutting tools sharp and clean. Properly maintained tools with sharp cutting edges are less likely to bind and are easier to control.

Check for misalignment or binding of moving parts, breakage of parts and any other condition that may affect the tools operation. If damaged, have the tool serviced before using. Many accidents are caused by poorly maintained tools.

Use only accessories that are recommended by the manufacturer for your model. Accessories that may be suitable for one tool may become hazardous when used on another tool.

6. Service

Tool service must be performed only by qualified repair personnel. Service or maintenance performed by unqualified personnel could result in a risk of injury.

When servicing a tool, use only identical replacement parts. Follow instructions in the Maintenance section of this manual. Use of unauthorized parts or failure to follow Maintenance Instructions may create a risk of electric shock or injury.

en

3. Specific safety rules and symbols

Hold tools by insulated gripping surfaces when performing an operation where the cutting tool may contact hidden wiring or its own cord. Contact with a "live" wire will make exposed metal parts of the tool "live" and shock the operator.

Wear ear protectors when using the tool for extended periods. Prolonged exposure to high intensity noise can cause hearing loss.

Personal protective equipment

The user and any other persons in the vicinity must wear suitable eye protection, a safety helmet, ear protection and protective gloves. They must also wear breathing protection if no dust removal system is used.



Wear a safety helmet



Wear eye protection



Wear breathing protection



Wear ear protection



Wear protective gloves

Symbols used on the tool:

V volts

W watts

~ alternating current

Hz hertz

A amperes

n_0 no load speed

/min revolutions per minute

∅ diameter

 protective grounding

4. Functional description

The tool is an electrically powered rotary hammer drill and breaker with a pneumatic hammering mechanism. The ATC function TE 46-ATC/TE 56-ATC (active torque control) provides additional safety for the user when drilling. The tool is intended for professional use.

The tool is equipped with electronic overload protection. This reduces motor speed or, if necessary, stops the motor when the tool is subjected to sustained overload. The motor provides full power again as soon as the control switch is released and then pressed again. When restarting, care should thus be taken to ensure that the tool is held securely with both hands.

Correct use

The tool is designed for drilling in concrete and masonry. The tool may also be used for light to medium-duty chiseling work.

The working environment may be on a construction site or in a workshop and may consist of renovation, conversion or new building work.

Chucks (TE 46/TE 46-ATC)

– Quick-change chuck TE-T

Chucks (TE 56/TE 56-ATC)

– Quick-change chuck TE-Y (SDS max)

Switches

– Speed control switch for smooth hole starting

– Function selection switch for:

Hammer drilling

Drilling without hammering

Chiseling

Chisel adjustment (24 positions)

– Power selection: full power and reduced power

– Control switch lockable for chiseling

Grips

– Adjustable side handle with depth gauge

– Vibration-absorbing grip

Safety features

– Mechanical slip clutch

– Additional ATC "active torque control" system (TE 46-ATC/TE 56-ATC)

Lubrication

– Gearing and hammering mechanism with separate lubrication chambers

Indicator lamps

- Power indicators "full power" and "reduced power (50%)" (reduced power: orange)
- Service indicator (yellow)
- Anti-theft system indicator (available as option) (blinks yellow)

See figure **1** and the explanations of operating controls and components on page 1.

en

The following items are supplied as standard

- Tool
- Grease dispenser (50 ml)
- Operating instructions
- Toolbox
- Cleaning cloth

Technical data

Rated power input	TE 46 / TE 46-ATC	1050 W
	TE 56 / TE 56-ATC	1100 W
Rated voltage		120 V
Rated current input	TE 46 / TE 46-ATC	13.6 A
	TE 56 / TE 56-ATC	14.2 A
Mains frequency		50–60 Hz
Weight of tool	TE 46 / TE 56	5.9 kg (13 lbs)
	TE 46-ATC / TE 56-ATC	6.6 kg (14.5 lbs)
Dimensions (l × w × h)	TE 46	468×95×240 mm (18.4×3.7×9.4 in)
	TE 46-ATC	468×95×260 mm (18.4×3.7×10.2 in)
	TE 56	475×95×240 mm (18.7×3.7×9.4 in)
	TE 56-ATC	475×95×260 mm (18.7×3.7×10.2 in)
Hammer drilling speed		480 r.p.m.
Drilling speed without hammering action	TE 46-ATC / TE 56-ATC	720 r.p.m.
Single impact energy (full hammering power)		7.0 Nm (J)
Single impact energy (reduced hammering power)		3.5 Nm (J)
Drill bit diameter range in concrete / masonry (hammer drilling)	TE 46 / TE 46-ATC	6–32 mm dia. (1/4"–1 1/4" dia.)
	TE 56 / TE 56-ATC	12–40 mm dia. (1/2"–1 1/2" dia.)
Breach bits	TE 46 / TE 46-ATC	40 mm dia. (1 1/2" dia.)
	TE 56 / TE 56-ATC	40–66 mm dia. (1 1/2"–2 3/4" dia.)
Percussion core bits	TE 46 / TE 46-ATC	50–90 mm dia. (2"–3 1/2" dia.)
	TE 56 / TE 56-ATC	45–90 mm dia. (1 3/4"–3 1/2" dia.)
Diamond core bits PCM	TE 46-ATC / TE 56-ATC	42–87 mm dia. (1 5/8"–3 3/16" dia.)
Diameter range with drill bits for wood		10–32 mm dia. (3/8"–1 1/4" dia.)
Diameter range with drill bits for metal		Up to 20 mm dia. (3/4" dia.)
Drilling performance in medium-hard concrete		20 dia.: 350 mm/min. (3/4" dia.: 13.8 in/min.)
Mechanical slip clutch		
ATC active torque control (TE 46-ATC/TE 56-ATC)		
Vibration-absorbing grip and side handle		

Right of technical changes reserved

5. Assembly



Ensure that the tool is disconnected from the mains supply.

5.1 Fitting the side handle 2

1. Release the side handle clamping band by turning the handle in a counter-clockwise direction.
2. Fit the side handle clamping band over the chuck and onto the cylindrical section of the gear housing.
3. Pivot the side handle into the desired position.
4. Secure the side handle by turning the handle in a clockwise direction.

5.2 Fitting the depth gauge 3

1. Release the side handle clamping band by turning the handle in a counter-clockwise direction.
2. Slide the depth gauge through the two guide holes in the depth gauge holder on the side handle clamping band. (The depth gauge can be clamped in position above the tool or pivoted through 90° to the side of the tool opposite the function selection switch.)
3. Secure the side handle by turning the handle in a clockwise direction.

5.3 Use of extension cords

Use only extension cords of a type approved for the application and with conductors of adequate cross section. Recommended minimum conductor cross section and max. cable lengths:

Mains voltage	Conductor cross section				AWG	
	1,5 mm ²	2,0 mm ²	2,5 mm ²	3,3 mm ²	14	12
100 V	–	30 m	–	50 m	–	–
110–120 V	20 m	30 m	40 m	50 m	75 ft	125 ft
220–240 V	50 m	–	100 m	–	–	–

Do not use extension cords with 1.25 mm² or 16 AWG conductor cross sections.

5.4 Use of a generator or transformer

This tool may be powered by a generator or transformer which fulfils the following conditions:

- AC voltage output, power output at least 2600 W
 - The operating voltage must be within +5% and –15% of the rated voltage at all times.
 - Frequency range 50–60 Hz, never above 65 Hz
 - Automatic voltage regulation with starting boost
- Never operate other tools or appliances from the generator or transformer at the same time. Switching other tools or appliances on and off may cause undervoltage and / or overvoltage peaks, resulting in damage to the tool.

5.5 Activating the tool

See operating instructions TPS theft protection systems.

6. Operation



Never use the tool without the side handle.
Use a vice or clamp to secure loose workpieces.

-CAUTION-	
	<ul style="list-style-type: none"> ● The insert tool may become hot during use. ● There is a risk of burning the hands. ● Wear protective gloves when changing insert tools.

6.1 Fitting the insert tool 4

1. Unplug the supply cord from the mains socket.
2. Check that the connection end of the insert tool is clean and lightly greased. Clean it and grease it if necessary.

3. Check that the sealing lip of the dust shield is clean and in good condition. Clean the dust shield if necessary or replace it if the sealing lip is damaged (see section 8).
4. Insert the insert tool in the chuck and rotate it while applying slight pressure until it engages in the guide grooves.
5. Push the insert tool further into the chuck until it is heard to engage.
6. Check that the insert tool has engaged correctly by pulling on it.



6.2 Removing the insert tool 5

1. Unplug the supply cord from the mains socket.
2. Open the chuck by pulling back the locking sleeve.
3. Pull the insert tool out of the chuck.

6.3 Adjusting the depth gauge 6

1. Release the depth gauge clamping screw.
2. Slide the depth gauge into the desired position.
3. Tighten the depth gauge clamping screw.

6.4 Hammer drilling – full hammering power  **7**

  	-CAUTION-
	<ul style="list-style-type: none"> ● Drilling may cause splintering of the material. ● Splinters may cause injury to parts of the body and eyes. ● Wear eye protection, protective gloves and breathing protection if no dust removal system is used.

	-CAUTION-
	<ul style="list-style-type: none"> ● The tool and the drilling operation emit noise. ● Excessive noise may damage the hearing. ● Wear ear protection.

- Engage the function selection switch in the "hammer drilling / full hammering power" position.
- Bring the side handle into the desired position and check that it is correctly fitted and properly secured.
- Plug the supply cord into the mains socket.
- Set the desired drilling power.
 - Full drilling power: Full drilling power is always activated after plugging the supply cord into the mains socket.
 - Reduced drilling power (50%): Press the "reduced drilling power" button (the drilling power indicator lights.) To return to full drilling power, press the "reduced drilling power" button again.
- Position the tip of the drill bit at the point where the hole is to be drilled.
- Press the control switch slowly. Begin drilling at low speed, increasing speed only after the drill bit has become centered in the hole.
- Press the control switch fully to continue drilling at full power.
- Do not apply excessive pressure to the tool. This will not increase its hammering power. Lower contact pressure increases the life of the insert tool.
- To avoid spalling when drilling through-holes with breach bits, reduce drilling speed shortly before breaking through.

-NOTE-
 When working at low temperatures:
 The hammering mechanism works only when the tool has reached a minimum operating temperature. Bring the drill bit into contact with the base material and allow the tool to run under no load until the minimum operating temperature is reached. If necessary, repeat

this procedure until the hammering mechanism begins to operate.

Active torque control (TE 46-ATC/TE 56-ATC)

The TE 46-ATC/TE 56-ATC is equipped with an **active torque control** system in addition to the mechanical clutch. This system offers additional safety while drilling by quickly switching off the tool, for example, when the drill bit sticks on contacting a reinforcing bar or when the insert tool is tilted unintentionally, thus preventing uncontrolled rotation around the longitudinal axis of the drill bit.

When the torque control system has become activated, the tool can be returned to normal operating mode by releasing pressure on the control switch, waiting until the motor has stopped rotating and then reapplying pressure to the control switch. (An audible "click" indicates that the tool is again ready for operation). Always choose a working position in which the electric tool is free to rotate in a counter-clockwise direction (as seen by the operator). If this is not possible, the ATC system cannot react.

6.5 Drilling without hammering action () **8**
 (only TE 46-ATC/TE 56-ATC)

- Engage the function selection switch in the "rotary drilling" position.
- Bring the side handle into the desired position and check that it is correctly fitted and properly secured.
- Plug the supply cord into the mains socket.
- Position the tip of the drill bit at the point where the hole is to be drilled.
- Press the control switch slowly. Begin drilling at low speed, increasing speed only after the drill bit has become centered in the hole.
- Press the control switch fully to continue drilling at full power.
- Do not apply excessive pressure to the tool. This will not increase its hammering power. Lower contact pressure increases the life of the insert tool.

6.6 Chiseling ( / ) **9**

-NOTE-
 The chisel can be locked in 24 different positions (in 15° increments). Flat and shaped chisels can thus always be brought into the optimum position for the job on hand.

6.6.1 Chisel positioning ()

- Turn the function selection switch to the "chisel adjustment" position until it engages.
- Pivot the side handle into the desired position and check that it is fitted and secured correctly. (Alternatively, when chiseling, the tool may be held at the section of the housing behind the chuck.)
- Adjust the chisel to the desired position.

6.6.2 Locking the chisel ()

- Turn the function selection switch to the "chiseling" position until it engages.

6.6.3 Chiseling ()

5. Plug the supply cord into the mains socket.
6. Set the desired chiseling power.
 - Full chiseling power: Full chiseling power is always activated after plugging the supply cord into the mains socket.
 - Reduced chiseling power (50%): Press the "reduced chiseling power" button (the chiseling power indicator lights.) To return to full chiseling power, press the "reduced chiseling power" button again.
7. Position the tip of the chisel at the desired position on the work surface.
8. Press the control switch fully.

6.6.4 Using the control switch lockbutton

The control switch can be locked in the "on" position when chiseling.

Locking the switch

1. Slide the control switch lockbutton (above the grip) forward.
2. Press the control switch fully. (The tool is then in sustained operating mode.)

Releasing the switch

1. Slide the control switch lockbutton back. (The tool switches off.)

en

7. Care and maintenance

Unplug the supply cord from the mains socket.

7.1 Care of insert tools

Clean off dirt and dust deposits and protect your insert tools from corrosion by wiping them from time to time with an oil-soaked rag.

7.2 Care of the electric tool

The outer casing of the tool is made from impact-resistant plastic. Sections of the grip are made from an elastomer material.

Never operate the tool when the ventilation slots are blocked. Clean the ventilation slots carefully using a dry brush. Do not permit foreign objects to enter the interior of the tool. Clean the outside of the tool at regular intervals using a slightly damp cloth. Do not use a spray, steam pressure cleaning equipment or running water for cleaning. This may negatively affect the electrical safety of the tool. Always keep the grip surfaces of the tool free from oil and grease. Do not use cleaning agents which contain silicone.

7.3 Service indicator

The tool is equipped with a service indicator.

7.3.1 The service indicator lights

The carbon brushes have reached the end of their life. The tool can be operated for a further approx. eight hours after the service indicator lights, after which the automatic cut-out will be activated. Please return the tool to a Hilti service center in good time so that it is ready for use when required.

7.3.2 The service indicator blinks

An electrical fault has occurred. The tool has been rendered inoperable and should be returned to a Hilti repair center for servicing.

7.4 Maintenance

Check all external parts of the tool for damage at regular intervals and check that all controls operate faultlessly. Do not operate the tool if parts are damaged or when the controls do not function faultlessly. If necessary, your electric tool should be repaired at a Hilti repair center. Repairs to the electrical section of the tool may be carried out only by trained electrical specialists

7.5 Checks after care and maintenance

After carrying out care and maintenance on the tool, check that all protective equipment has been refitted and that all items function faultlessly.

8. Tools and accessories

Chucks	TE 46 / TE 46-ATC TE 56 / TE 56-ATC	TE-T TE-Y
Hammer drill bits	TE 46 / TE 46-ATC TE 56 / TE 56-ATC	6–32 mm dia. ($\frac{1}{4}$ "– $1\frac{1}{4}$ " dia.) 12–40 mm dia. ($\frac{1}{2}$ "– $1\frac{1}{2}$ " dia.)
Breach bits	TE 46 / TE 46-ATC TE 56 / TE 56-ATC	40 mm dia. ($1\frac{1}{2}$ " dia.) 40–66 mm dia. ($1\frac{1}{2}$ "– $2\frac{3}{4}$ " dia.)
Percussion core bits	TE 46 / TE 46-ATC TE 56 / TE 56-ATC	50–90 mm dia. (2 "– $3\frac{1}{2}$ " dia.) 45–90 mm dia. ($1\frac{3}{4}$ "– $3\frac{1}{2}$ " dia.)
Diamond core bits PCM	TE 46 / TE 56 TE 46-ATC / TE 56-ATC	– 42–87 mm dia. ($1\frac{5}{8}$ "– $3\frac{3}{16}$ " dia.)
Chisels	TE 46 / TE 46-ATC TE 56 / TE 56-ATC	Pointed, flat and shaped chisels with TE-T connection end with TE-Y connection end
Setting tools	TE 46 / TE 46-ATC TE 56 / TE 56-ATC	Setting tools with TE-T connection end Setting tools with TE-Y connection end
Quick-release chuck	TE 46 / TE 46-ATC TE 56 / TE 56-ATC	Quick-release chuck 60208 for wood and metal drill bits with cylindrical or hex. shank Chuck holder 264758 Chuck holder 263359
Wood drill bits		10–32 mm dia. ($\frac{3}{8}$ "– $1\frac{1}{4}$ " dia.)
Metal drill bits		Up to 20 mm dia. ($\frac{3}{4}$ " dia.)
Mixing non-inflammable substances		Mixing paddles with cylindrical or hex. shanks of 80–150 mm dia. ($3\frac{1}{8}$ "– 6 " dia.)
Dust removal system		TE DRS-S 340602

9. Troubleshooting

Fault	Possible cause	Remedy
The tool doesn't start	Fault in mains supply	Plug in another electric appliance and check whether it works.
	Supply cord or plug defective	The cord should be checked and, if necessary, replaced by an electrical specialist.
	Control switch defective	The switch should be checked and, if necessary, replaced by an electrical specialist.
No hammering action	The tool is too cold	Allow the tool to warm up to the minimum operating temperature. (See "Operation".)
	Function selection switch set to rotary drilling (TE 46-ATC/TE 56-ATC)	Set the function selection switch to hammer drilling.
The tool does not achieve full power.	Extension cord with inadequate cross section used	Use an extension cord with adequate cross section. (See "Before use".)
	Control switch not fully pressed	Press the control switch as far as it will go.
	"Reduced power" button activated	Press the "reduced power" button (fig. 1).
Drill bit doesn't rotate	Function selection switch not engaged	<u>After rotation has stopped</u> , move the function selection switch until it engages.
The drill bit cannot be released from the chuck	Chuck sleeve not pulled back fully	Pull the chuck sleeve back as far as it will go and remove the insert tool.
	Side handle not correctly fitted or moved out of place	Release the side handle and reposition it correctly so that the clamping band and side handle are engaged in the groove. (See 5.1)

10. Disposal

Most of the materials from which Hilti electric tools are manufactured can be recycled. The materials must be correctly separated before they can be recycled. In many countries, Hilti has already made arrangements for taking back your old electric tools for recycling. Please ask your Hilti customer service department or Hilti representative for further information.

Should you wish to return the electric tool yourself to a disposal facility for recycling, proceed as follows: Dismantle the electric tool as far as possible without the need for special tools. Use absorbent paper to wipe oily parts clean and to collect any grease that runs out (total quantity approx. 50 ml). This paper should also be disposed of correctly. **On no account should oil or grease be allowed to enter the waste water system or to find its way into the ground.**

The individual parts should be separated as follows:

Part / assembly	Main material	Recycling
Toolbox	Plastic	Plastics recycling
Gear housing	Plastic with magnesium alloy / brass parts	Scrap metal
Bearing plate	Magnesium alloy / brass	Scrap metal
Grip, side handle	Plastic	Plastics recycling
Motor housing	Plastic	Plastics recycling
Grip cover	Plastic	Plastics recycling
Fan	Plastic	Plastics recycling
Motor (rotor and stator)	Steel and copper	Scrap metal
Supply cord	Copper, elastomer	Scrap metal
Gearing parts	Steel	Scrap metal
Hammering mechanism parts	Steel	Scrap metal
Screws, small parts	Steel	Scrap metal

11. Warranty

Hilti warrants that the tool supplied is free of defects in material and workmanship. This warranty is valid so long as the tool is operated and handled correctly, cleaned and serviced properly and in accordance with the Hilti Operating Instructions, all warranty claims are made within 12 months from the date of the sale (invoice date), and the technical system is maintained. This means that only original Hilti consumables, components and spare parts may be used in the tool. This warranty provides the free-of-charge repair or replacement of defective parts only. Parts requiring repair or replacement as a result of normal wear and tear are not covered by this warranty.

Under no circumstances will Hilti be obligated for direct, indirect, incidental or consequential dam-

ages, losses or expenses in connection with, or by reason of, the use of, or inability to use the tool for any purpose. Hilti specifically excludes the implied warranties of merchantability and fitness for a particular purpose.

For repair or replacement, send tool and/or related parts immediately upon discovery of the defect to the address of the local Hilti marketing organization provided.

This constitutes Hilti's entire obligation with regard to warranty and supersedes all prior or contemporaneous comments and oral or written agreements concerning warranties.

